



Visit our homepage
for additional support
parker.com/pmde

Bulletin MSG30-8223-INST/EU

Installation and start-up information Hydraulic Motors Series V12, V14, V16

Effective: March 30, 2022
Supersedes: August 22, 2016



V12



V14



V16



ENGINEERING YOUR SUCCESS.

Direction of rotation versus flow

NOTE: The V12, V14 and V16 motors are bi-directional.

V12, V16 rotation:

- End cap position T (AC and AH controls): When port B (open arrow) is pressurized, the motor rotates clockwise (right hand; R), and when port A (black arrow) is pressurized, the motor turns counter clockwise (left hand; L)
- End cap position M (EO, EP, HO and HP controls): A and B port positions interchange (A-to-B, B-to-A).

V14 rotation:

- Refer to the V14 illustration below right (valid for all compensators and controls).

NOTE:

Before installing a V12, V14 or V16 motor in series (when both A and B ports can be subject to high pressures simultaneously) contact Parker Hannifin).

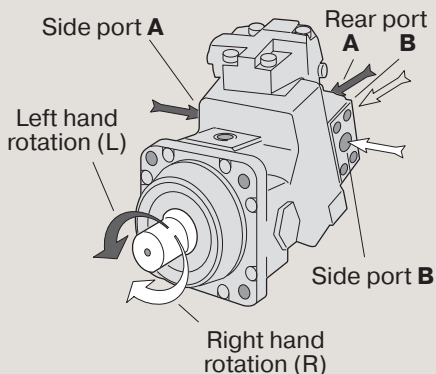

Direction of rotation vs. flow for the V12, V16 motor (V12 shown, here with AC-compensator; end cap position T).

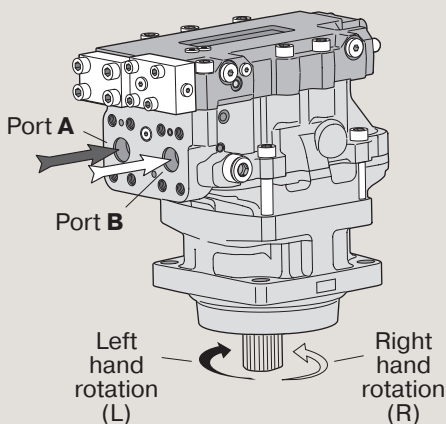

Direction of rotation vs. flow for the V14 motor (shown with AC-compensator).

Filtration

Maximum motor service life is obtained when the fluid cleanliness meets or exceeds ISO code 20/18/13 (ISO 4406). A 10µm (absolute) filter is recommended.

Case pressure

To secure correct case pressure and lubrication, a spring loaded check valve, 1 – 3 bar, in the drain line (shown on next page) is recommended.

NOTE: Contact Parker Hannifin for information when operating at high speeds.

Frame size	1500	3000	4000	5000	6000
V12-60	max 12	0.5 – 7	1 – 5.5	1.5 – 5	2 – 5
V12-80	max 12	0.5 – 7	1 – 5.5	1.5 – 5	2.5 – 5
V14-110	max 10	1 – 6	1.5 – 5	2 – 4.5	3 – 5
V14-160	max 10	1 – 6	2 – 5.5	2.5 – 5.5	-
V16-220	max 8	2 – 6	3 – 5.5	4 – 5	-
V16-270	max 8	2 – 6	3 – 5.5	4 – 5	-

Min and max case pressure [bar] vs. shaft speed [rpm].

Required inlet pressure

The motor may operate as a pump under certain conditions. When this occurs, a minimum pressure must be maintained at the inlet port; increased noise and gradually deteriorating performance due to cavitation may otherwise be experienced.

A 15 bar inlet pressure, measured at the motor inlet port, satisfies most operating conditions.

Contact Parker Hannifin for more specific information on inlet pressure requirements.

Operating temperatures

The following temperatures should not be exceeded

Main circuit: 80 °C.
 Drain fluid: 115 °C.

Continuous operation at high power levels usually requires case flushing in order for the fluid to stay above the minimum viscosity requirement. A flushing valve and restricting nozzle, available as an option, provide the necessary main circuit flushing flow.

Drain ports

There are two drain ports on the V12, V16 and three on the V14 motors. The uppermost drain port should always be utilized.

In order to avoid excessively high case pressure, the drain line should be connected directly to the reservoir.

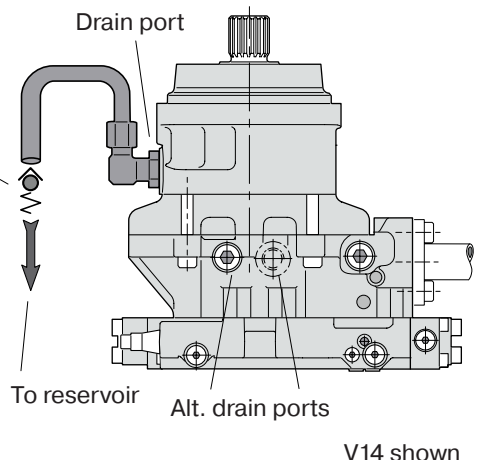
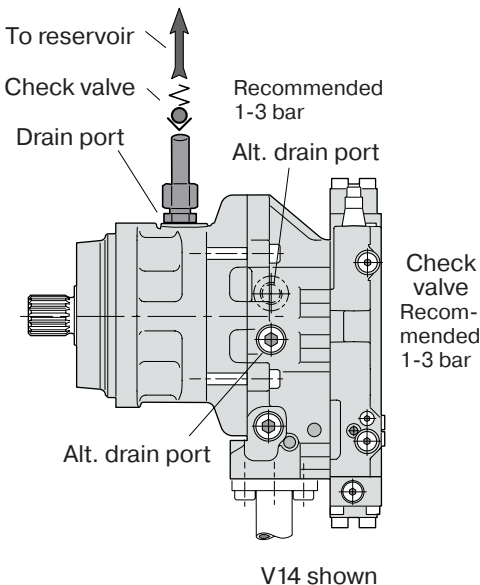
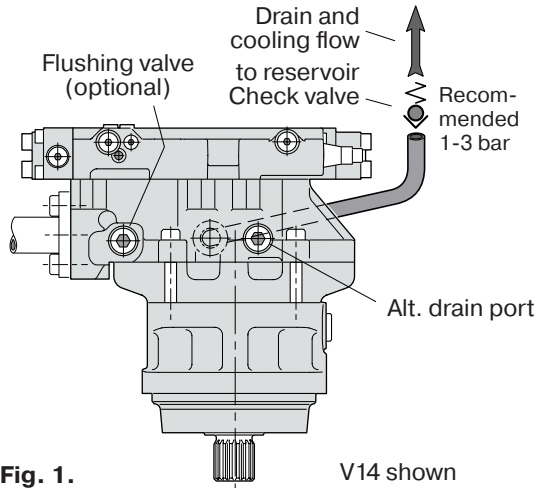

Hydraulic fluids

Ratings and performance data for the motors are valid when a good quality, contamination-free, petroleum-based fluid is used in the hydraulic system.

Hydraulic fluids type HLP (DIN 51524), automatic trans-mission fluids type A, or API CD engine oils can be used.

When the hydraulic system has reached full operating temperature, the motor drain oil viscosity should be above 8 mm²/s (cSt).

At start-up, the viscosity should not exceed 1500 mm²/s.

The ideal operating range for the motor is 15 to 30 mm²/s.

Fire resistant fluids, when used under modified operating conditions, and synthetic fluids are also suitable.

Contact Parker Hannifin for additional information about:

- Hydraulic fluid specifications
- Fire resistant fluids.

Before start-up

Make sure the motor case as well as the entire hydraulic system is filled with hydraulic fluid.

The internal leakage, especially at low operating pressures, is not sufficient to provide lubrication at start-up.

High Speed/High Power operation Running in procedure at mid. displacement

Running in procedure Parker Motors

We suggest the following procedure to run in the V12/V14/V16 motors.

1. Start @ 500 rpm, differential pressure 250 bar, outlet 10 – 15 bar.
 2. Run until the drain temperature has passed its maximum* and has decreased 1 – 2 °C
 3. Increase differential pressure to 350 bar
 4. Run until the drain temperature has passed its maximum* and has decreased 1 – 2 °C
 5. Increase differential pressure to 400 bar
 6. Run until the drain temperature has passed its maximum* and has stabilized.
- *If, at any point, the temperature tends to pass 100 °C, decrease the pressure at once. Please make sure the drain temperature probe is in the drain oil flow to measure the correct temp.

Running In Example:

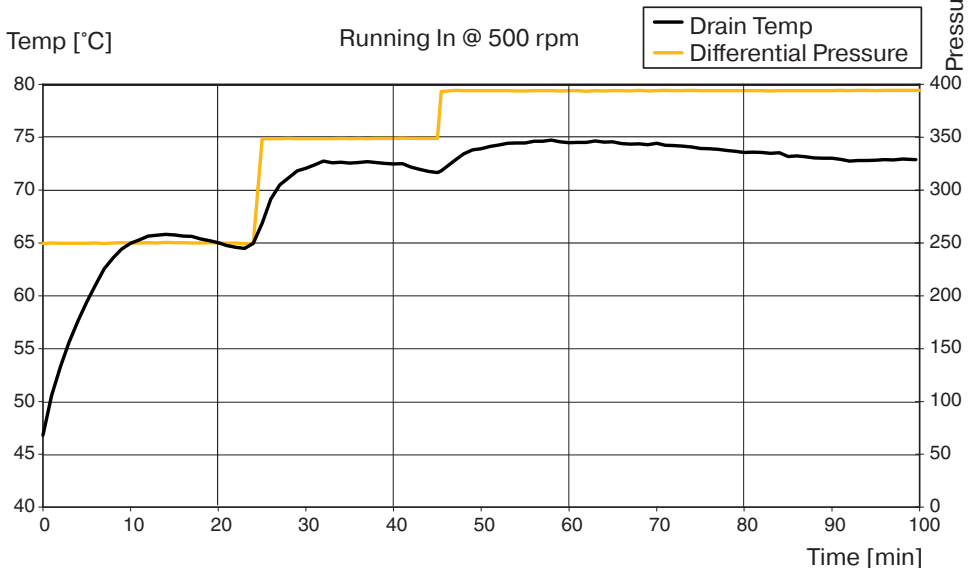

Notes

A series of horizontal dotted lines for taking notes.

Position notification regarding Machinery Directive 2006/42/EC:

Products made by the Pump & Motor Division Europe (PMDE) of Parker Hannifin are excluded from the scope of the machinery directive following the "Cetop" Position Paper on the implementation of the Machinery Directive 2006/42/EC in the Fluid Power Industry.

All PMDE products are designed and manufactured considering the basic as well as the proven safety principles according to:

- ISO 13849-1:2015
- SS-EN ISO 4413:2010

so that the machines in which the products are incorporated meet the essential health and safety requirements.

Confirmations for components to be proven component, e. g. for validation of hydraulic systems, can only be provided after an analysis of the specific application, as the fact to be a proven component mainly depends on the specific application.

Dr. Hans Haas
General Manger
Pump & Motor Division Europe



WARNING – USER RESPONSIBILITY

FAILURE OR IMPROPER SELECTION OR IMPROPER USE OF THE PRODUCTS DESCRIBED HEREIN OR RELATED ITEMS CAN CAUSE DEATH, PERSONAL INJURY AND PROPERTY DAMAGE.

This document and other information from Parker-Hannifin Corporation, its subsidiaries and authorized distributors provide product or system options for further investigation by users having technical expertise.

The user, through its own analysis and testing, is solely responsible for making the final selection of the system and components and assuring that all performance, endurance, maintenance, safety and warning requirements of the application are met. The user must analyze all aspects of the application, follow applicable industry standards, and follow the information concerning the product in the current product catalogue and in any other materials provided from Parker or its subsidiaries or authorized distributors.

To the extent that Parker or its subsidiaries or authorized distributors provide component or system options based upon data or specifications provided by the user, the user is responsible for determining that such data and specifications are suitable and sufficient for all applications and reasonably foreseeable uses of the components or systems.

Offer of Sale

Please contact your Parker representation for a detailed "Offer of Sale".



Parker Hannifin Manufacturing Sweden AB

Pump & Motor Division Europe
Flygmotorvägen 2
461 82 Trollhättan
Sweden
Tel. +46 (0)520 40 45 00
www.parker.com/pmde

MSG30-8223-INST/EU

© Copyright 2022
All rights reserved